

# RING MEGA POLE COB, HP

-COD. 807013

-COD. 807014

-COD. 807015

-COD. 807016



-Class II double insulated luminaire (not earthed)



-replace the damaged protective glass  
-In case of replacement of damaged glass, contact the manufacturer of the fixture for replacement



-getting rid of as urban waste forbidden  
-separate collection is mandatory when the product is at the end of its life



Made in Italy

IP66



GB Retain the instructions.  
I Conservare le istruzioni.  
D Retain the instructions.  
F Bewahren Sie die Anleitung.  
E Conservez ces instructions.



The article is suitable for indoor and outdoor use

NB: These assembly instructions must be given to end users for correct maintenance and so that they know how to change the bulb. The appliance must not be tampered with or transformed and it must be installed and used as supplied and in compliance with the National Rules on Installations. Any non-compliant installations will invalidate all forms of guarantee. The company cannot be held

## COD. 807013

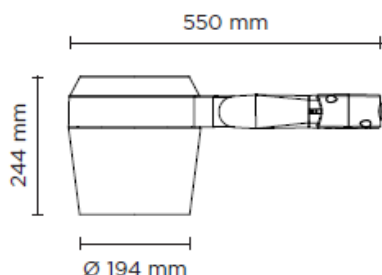

### RING MEGA POLE COB

-Power consumption : 82W  
-Voltage : 220-240V 50-60Hz  
-Color Temperature : 3000K - 4000K  
-Beam angle : 20°-40°  
-Insulation class: II  
-IK rating : IK10  
-IP protection: IP66  
-Gross weight: 8.5g

## COD. 807015

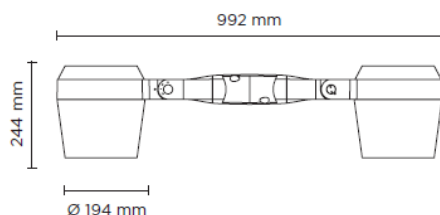

### DOUBLE RING MEGA POLE COB

-Power consumption : 2X82W  
-Voltage : 220-240V 50-60Hz  
-Color Temperature : 3000K - 4000K  
-Beam angle : 4°-10°-28°  
-Insulation class: II  
-IK rating : IK10  
-IP protection: IP66  
-Gross weight: 16.5kg

## COD. 807014

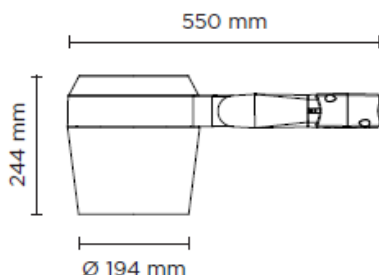

### RING MEGA POLE HP

-Power consumption : 88W  
-Voltage : 220-240V 50-60Hz  
-Color Temperature : 3000K - 4000K  
-Beam angle : 4°-10°-28°  
-Insulation class: II  
-IK rating : IK10  
-IP protection: IP66  
-Gross weight: 8.5kg

# COD. 807016

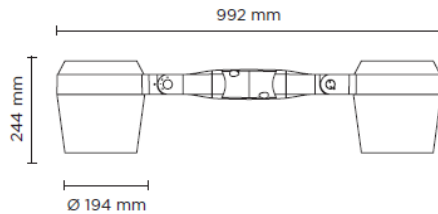

## DOUBLE RING MEGA POLE HP

- Power consumption : 2X88W
- Voltage : 220-240V 50-60Hz
- Color Temperature : 3000K - 4000K
- Beam angle : 4°-10°-28°
- Insulation class: II
- IK rating : IK10
- IP protection: IP66
- Gross weight: 16.5kg

### Installation:

- Open the pole clamp unscrewing 4 hexagonal head screws using the tool included in the package (pic. 1)
- Prepare a hole in the pole in the desired position (pic. 2)
- Make the electrical connection (pic. 3)
- Place the luminaire on the pole (pic. 4) (for poles with 60mm diameter use the plastic adapters, for poles with 76mm diameter remove them)
- Tighten the 4 screws using the proper tool (pic. 5)
- Adjust the desired angle of the luminaire unscrewing and the grub screws using the tool included in the package. Then tighten the grub screws (pic. 6)

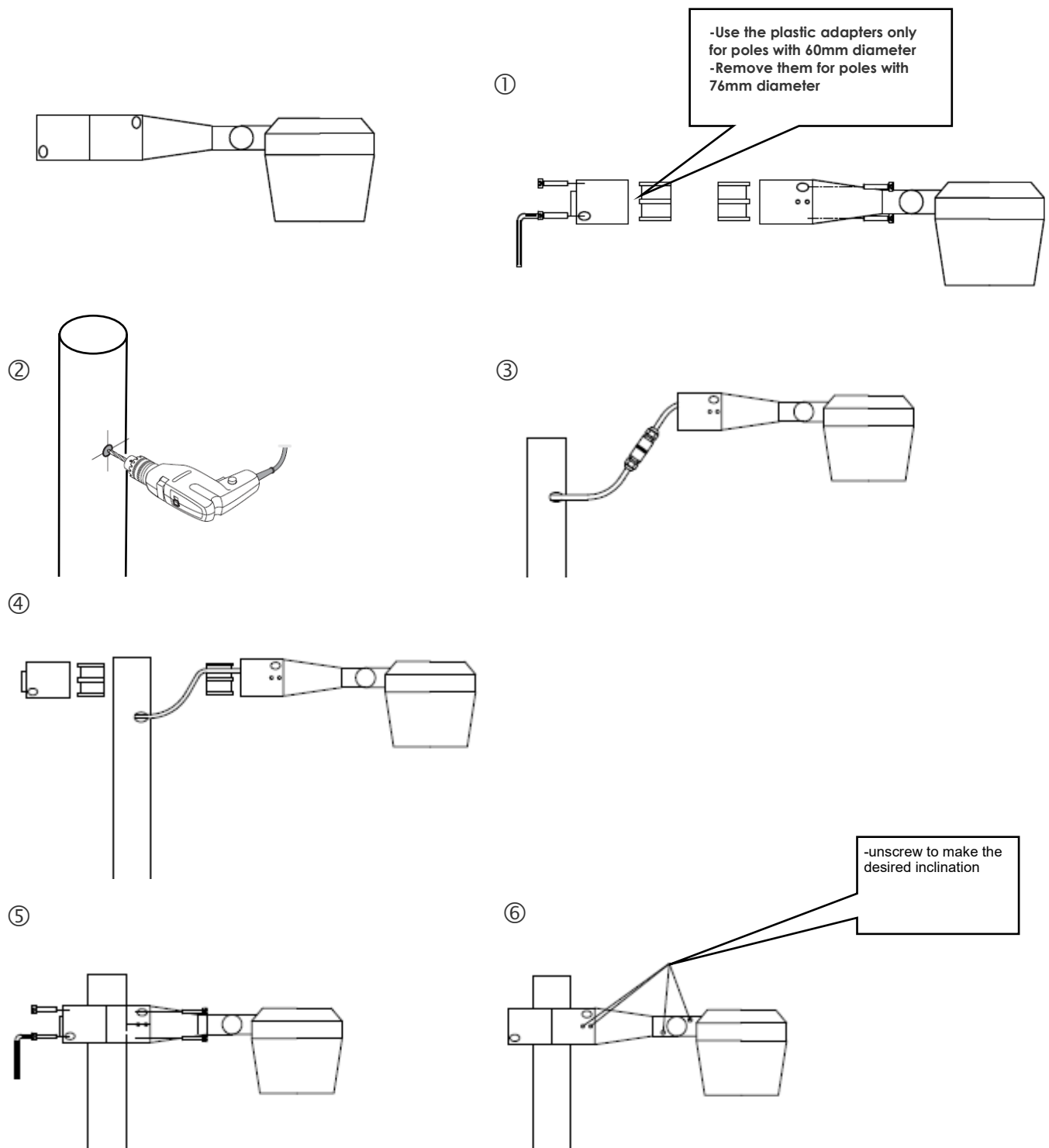

### -Recommendations

- 1) The light source contained in this luminaire must only be replaced by the manufacturer or its assistance service or by equally qualified personnel
- 2) verify that the equipment used to connect our devices to enjoy all the guarantees required under European law;
- 3) use the cables, connectors and quality materials for electrical wiring;
- 4) Products with IP66 degree make the wiring / connections with accessories provide the same degree IP of the selected product (available in the catalog);
- 5) In the case of installations outside is not recommended to install the power supplies in the formwork and / or in the junction box without adequate protection
- 6) Honey-comb louvre must be installed directly from the manufacturer . Please mention it during the order
- 7) the terminal block / connector for connecting to the power supply is not included, installation may require qualified personnel

### -Choice of installation location

The unit should be positioned so that when in use is not subject to direct radiation from the sun or other heat sources . High temperatures reduce the life and efficiency of the components or the LED module .

### -Note on corrosion protection

For installation and maintenance be especially careful not to damage the coating powder . Damage combined action of water could cause corrosion.

- 1) In the case of damage to the external flexible cable, it must be replaced by the manufacturer, or its assistance service, or equivalent qualified personnel in order to avoid dangers
- 2) In case of replacement of damaged glass, contact the manufacturer of the fixture for replacement

### -Photobiological risk: RG1 (low risk)

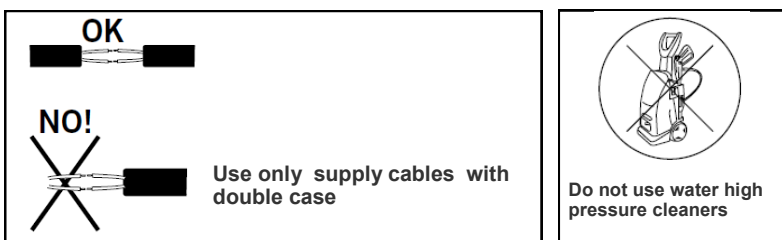

## AC085 POLE PLATE VERSION

### Installation:

- Prepare holes in the pole in the desired position making two M5 threads and one central hole used to pass through the cables and connectors (pic. 1)
- Place the pole plate gasket and make the electrical connection following the correct safety electrical rules. (pic. 2)
- Fix the luminaire to the pole tightening the two fixing screws (pic.3)
- Adjust the desired angle of the luminaire unscrewing and then tightening the two screws and the grub screws of the luminaire joint using the tools included in the package. (pic.4)

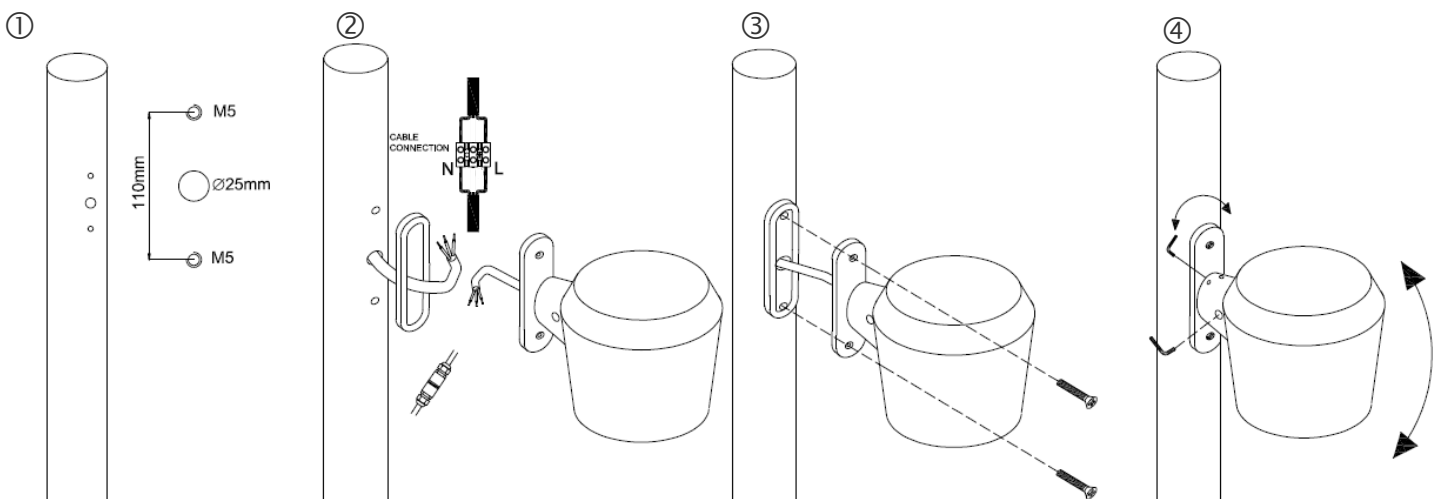

# AC089 TREE-BRANCH BRACKET VERSION

## Installation:

- Prepare holes in the pole in the desired position making two M8 threads and one central hole used to pass through the cables and connectors (pic. 1)
- Place the pole plate gasket and make the electrical connection following the correct safety electrical rules. (pic. 2)
- Fix the luminaire to the pole tightening the two fixing screws (pic.3)
- Adjust the desired angle of the luminaire unscrewing and then tightening the two screws and the grub screws of the luminaire joint using the tools included in the package. (pic.4)

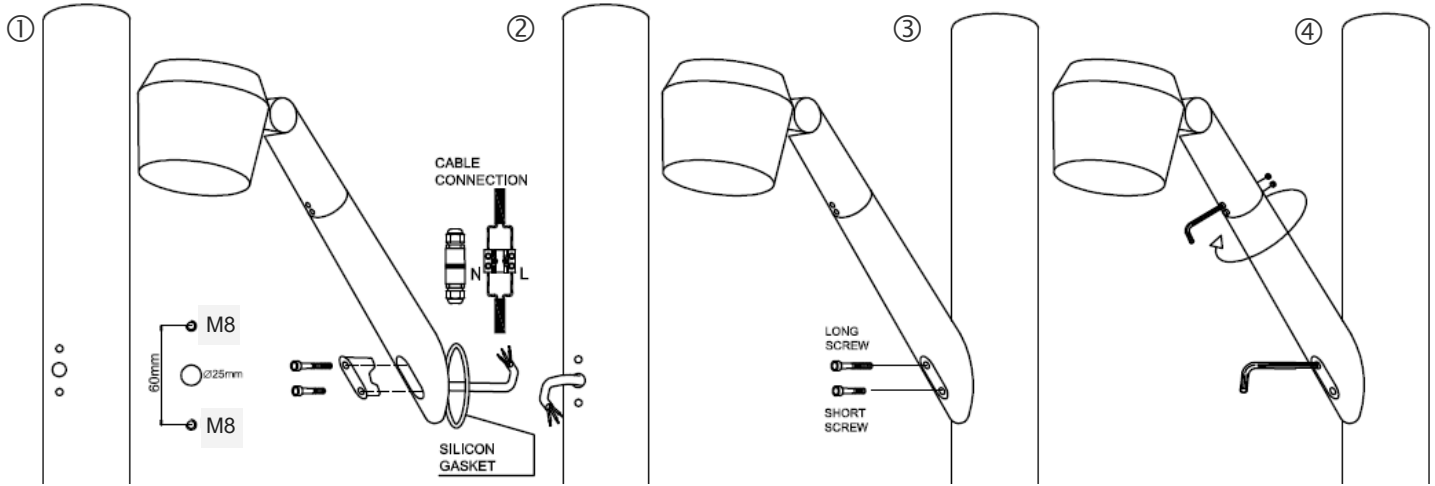

## ACCESSORIES

AC087  
HONEYCOMB  
LOUVER

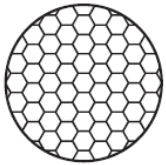

AC086  
ANTI-GLARE  
VISOR



**RAEE WEEE**

Directive 2002/96/CE (Waste Electrical and Electronic Equipment - RAEE-WEEE-DEE-AEEA: information for users

The crossed out wheeled bin label that can be found on your product indicates that this product should not be disposed of via the normal household waste stream. To prevent possible harm to the environment or human health please separate this product from other waste streams to ensure that it can be recycled in an environmentally sound manner. For more details on available collection facilities please contact your local government office or the retailer where you purchased this product.