

# HYDROWAY MEDIUM 01-02 ROUND LED

COD. 603003

COD. 603004

## ASSEMBLY AND OPERATING INSTRUCTIONS:



-Class I fitting electric grounding is needed

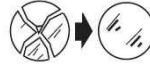

-replace the damaged protective glass

-glass features: plane float glass - safety tempered



-getting rid of as urban waste forbidden  
-separate collection is mandatory when the product is at the end of its life

**IP65**

-Complete protection from dust and water jets



Made in Italy



GB Retain the instructions.  
I Conservare le istruzioni.  
D Retain the instructions.  
F Bewahren Sie die Anleitung.  
E Conservez ces instructions.

**NB:** These assembly instructions must be given to end users for correct maintenance and so that they know how to change the bulb. The appliance must not be tampered with or transformed and it must be installed and used as supplied and in compliance with the National Rules on Installations. Any non-compliant installations will invalidate all forms of guarantee. The company cannot be held responsible for damage caused by incorrect assembly.

**COD. 603003**

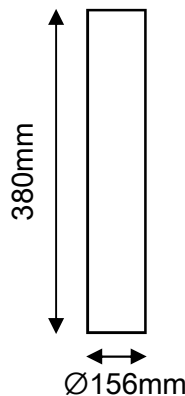

-Power consumption : 20W  
-Voltage :220/240V 50/60Hz  
-Color Temperature : 3000K  
-Lumen output: 1200lm  
-Lens Type : 360° beam  
-Insulation class: 1  
-IP protection: IP65  
-Gross weight: 4.3kg

**COD. 603004**

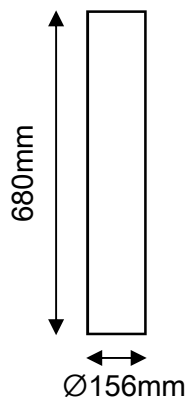

-Power consumption : 20W  
-Voltage :220/240V 50/60Hz  
-Color Temperature : 3000K  
-Lumen output: 1200lm  
-Lens Type : 360° beam  
-Insulation class: 1  
-IP protection: IP65  
-Gross weight: 5.2kg

### THE WARRANTY IS FALLING IN THE FOLLOWING CASES:

- 1) Malfunctions due to improper use of the product, modifications, repairs inadequate, negligence on the part of the installer / electrician, failure to assembly instructions and / or data plate;
- 2) Installations in plants not comply with the general safety;
- 3) Damage caused by natural causes such as lightning, fire or flooding;
- 4) Damage caused by wiring / connections with IP degree lower than the selected product.
- 5) Damage occurring during shipment of the product. In these cases the damage will be to charge and notify the carrier;
- 6) The warranty covers only the integrity of the product and NOT any costs of removal of the same;

## Recommendations

- 1) verify that the equipment used to connect our devices to enjoy all the guarantees required under European law;
- 2) use the cables, connectors and quality materials for electrical wiring;
- 3) Products with IP65/68 degree make the wiring / connections with accessories provide the same degree IP of the selected product (available in the catalog);
- 4) In the case of installations outside is not recommended to install the power supplies in the formwork and / or in the junction box without adequate protection

## Relamping and maintenance:

- The relamping must be done with maximum attention avoiding to dirty the sealing gasket and its contact surface. It is therefore necessary before opening the fixture to carefully wipe the floodlight then unscrew the round frame by the proper key
- If the gasket is damaged, deformed or not in perfect conditions it is necessary to change it
- it is essential to do a frequent cleaning of the glass and of the outer surface of the fixture to avoid build up of mud and dirtiness resulting in dangerous overheating due to uncorrect light and heat dissipation. Clean carefully the glass screen removing limestone deposits by means of a scraper.

**.The replacement must be done by a qualified electrician.**

## INSTALLATION:

### -SWITCH-OFF THE POWER SUPPLY BEFORE CARRYING OUT ANY MAINTENANCE OPERATION

- 1 Open the luminaire unscrewing three nuts using the hexagonal tool including in the package
- 2 Prepare holes in the floor in correspondance of the feeding point using plugs type ficher (not included in the package)
- 3 Fix the base to the floor by tighten the screws of the plugs
- 4 Open the upper cylinder of the luminaire uscrewing three nuts using the hexagonal tool
- 5 Insert the cable through the bottom rubber cable gland and move the cable into the cylindert to the cable connector
- 6 Make the electrical connection to the terminal.
- 7 Remount the luminaire tighten the 6 nuts using the hexagonal tool.

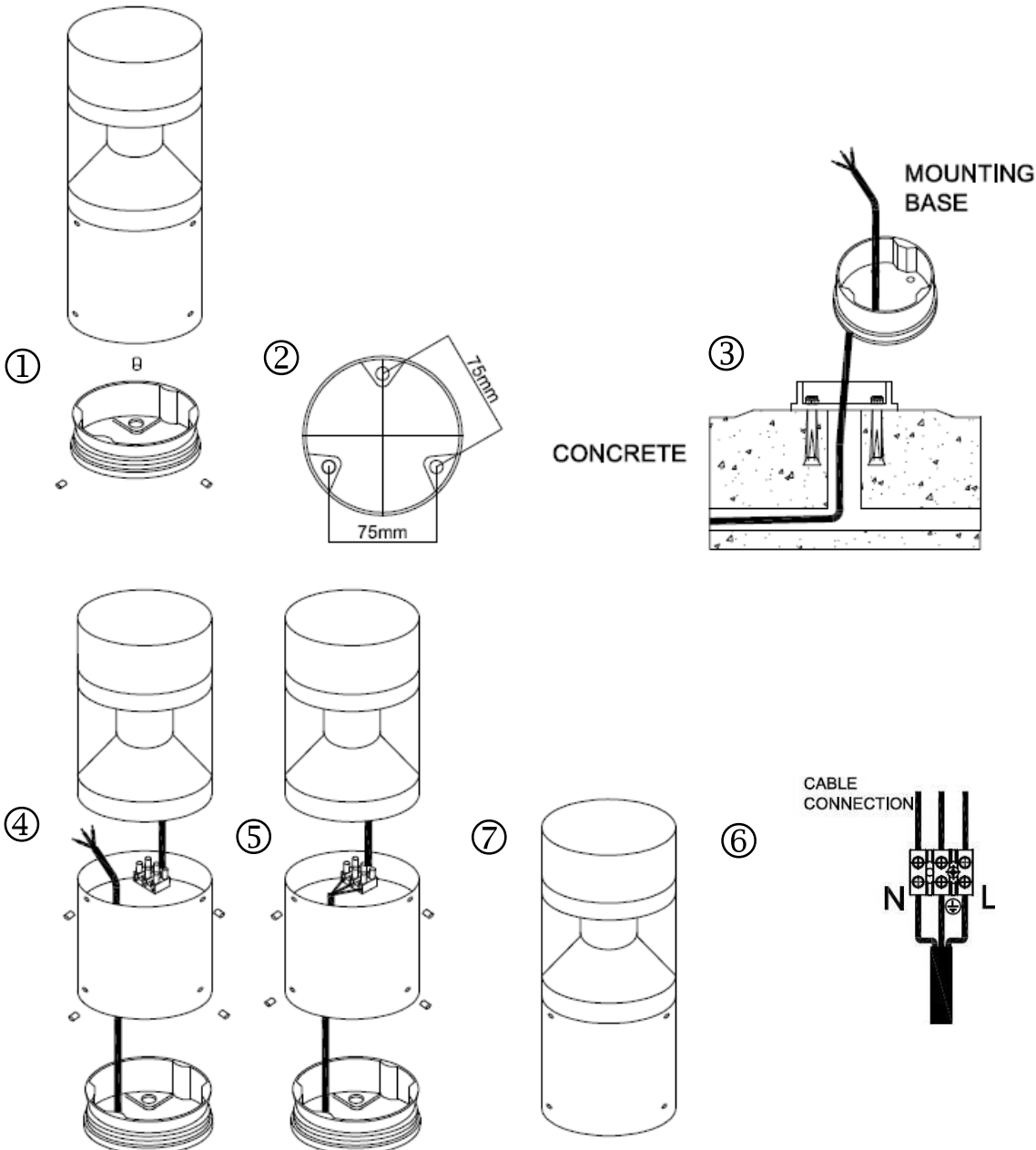

# Fixing accessory (included in the package)

## INSTALLATION:

**-SWITCH-OFF THE POWER SUPPLY BEFORE CARRYING OUT ANY MAINTENANCE OPERATION**

- 1 Mount three bracket to the triangle base by screwing them through the inner holes
- 2 Leave 24mm of free male screw see pic. 2
- 3 Place the complete fixing accessory into the concrete (see pic 3)
- 4 fix the luminaire tighten three nuts (for the installation see the previous page)

